

System for measuring the production CO₂ in soil contaminated with soybean oil using the Arduino platform

Emanuele Nunes de Lima Figueiredo Jorge¹, Claudio Miceli de Farias², Gabriel Martins de Oliveira Costa³, Tiago Cruz de França⁴, Mário Sérgio de Souza Pereira⁵, Marcelo Dolores de Carvalho⁶, Sérgio Thode Filho⁷

^{1,7} Professor at the Federal Institute of Education, Science and Technology of Rio de Janeiro - IFRJ, Campus Duque de Caxias, RJ, Multidisciplinary Laboratory Waste Management – LMGR. emanuele.jorge@ifrj.edu.br

² Professor of the Postgraduate Program in Informatics at the Federal University of Rio de Janeiro - UFRJ / NCE, Collaborator of the Multidisciplinary Laboratory of Waste Management – LMGR

³ Master Student of the Postgraduate Program in Informatics at the Federal University of Rio de Janeiro - UFRJ / NCE, Collaborator of the Multidisciplinary Laboratory of Waste Management – LMGR

⁴ Professor of the Federal Rural University of Rio de Janeiro - UFRRJ, Collaborator of the Multidisciplinary Laboratory of Waste Management – LMGR

^{5,6} Technician of Maintenance and Support in Informatics by the Federal Institute of Education, Science and Technology of Rio de Janeiro - IFRJ, Campus Duque de Caxias, RJ, Collaborator of the Multidisciplinary Laboratory of Waste Management – LMGR

Abstract

Carbon dioxide (CO₂), also known as carbonic gas, is a gaseous chemical compound. The process of the degradation of vegetable oil in the soil produces CO₂. There are methodologies that consist in determining the rate of CO₂ released by microorganisms in the process of degradation of organic compounds by chemical analysis. However, it is not easy to measure the amount of CO₂ released in this degradation process. Thus, the main objective of this work was to monitor in a continuous, quantitative and efficient way, through an automated and low cost system that uses the Arduino platform the amount of CO₂ produced in the degradation of vegetable oil in a contaminated soil. The results show the mean values of CO₂ capture as a function of the different periods of analysis. Thus, the development of work with automated systems that aid in agricultural environments becomes extremely important for the growth in the areas of Technological Innovation.

Keywords: Arduino, Biodegradation, Environment impact.

1. Introduction

The accelerated growth of the population and its excessive consumption of goods and services, has caused the increase of the anthropization process. With this process, the waste generated by the population impacts directly the urban and natural environments. For a long time there has been an inadequate disposition of the generated waste worldwide, especially the hazardous ones, without any environmental concern, causing pollution / contamination of the

soil and of all the ecosystem (BRAGA et al., 2002). One of the residues that contaminates the soil is the vegetable oil.

Vegetable oils are widely used for food production at different levels: domestic, commercial and industrial. The estimated production of vegetable oil, in Brazil, is of around three billion liters per year. Only 2.5% of cooking oil waste are recycled. The remaining is improperly discharged in the sewage system, becoming potentially polluting for water resources and can cause many problems to operation of wastewater treatment plants, provoking efficiency loss and increasing operational costs. (RABELO and FERREIRA, 2008; SABESP, 2011; ABIOVE, 2016). For the oil to reach the sewage system, most of the population still discards the product incorrectly, dumping it into the soil, into the sink or simply into the garbage.

Besides being the habitat of microorganisms, plants and animals, the soil is still responsible for the nutrient cycle, for maintaining the balance of oxygen / carbon dioxide in the atmosphere and is the final destination of most of the waste produced, mainly oil and fluids in general (LOUREIRO; NOGUEIRA, 2005).

When thrown directly into the soil, the oil occupies the spaces that would naturally be occupied by water and air, causing waterproofing. In addition, the fauna and flora of this place are prevented from absorbing the nutrients and end up dying, as well as their seeds that cannot germinate, making the soil unsuitable for cultivation. Another aspect that needs to be considered is that, when released into the soil, the oil comes into direct contact with the water that seeps through the pores and / or flows superficially. Depending on the physical-chemical characteristics of the soil and other characteristics such as relief and rainfall, it can migrate to reach water bodies and even the water table. The recovery of this soil, making it fertile and suitable for new crops becomes costly and difficult (SABESP, 2011; GALBIATI, 2005).

The process of degradation of vegetable oil in the soil produces CO₂. There are methodologies that consist in determining the rate of CO₂ released by microorganisms in the process of degradation of organic compounds by chemical analysis. These methodologies are capable of producing rapid results for large-scale testing. Considering that there is a correlation between CO₂ generation and the biodegradation of organic matter in the soil, it is possible to study the viability of different bioremediation methods before they are used in larger scales (GF COSTA FILHO, 2011).

The continuous monitoring of these factors allows obtaining information regarding the individual effects of the factors for the degradation of the oil in the soil. With the objective of developing low cost tools capable of assisting in the agricultural environment, we present a system to measure CO₂ production in soil contaminated with soybean oil using the Arduino platform. This article is divided into the parts described below. Materials and methods, which will describe the components used in the construction of the prototype. Results and discussion, which will present laboratory tests done with real data. And finally, the conclusion, with the final remarks of this work.

2. Materials and methods

2.1 Materials

For the present study, a soil with sandy texture, collected in a 0-20 cm horizon was used in the municipality of Pinheiral - RJ, geographic coordinates 22°29'03"S and 43°54'49"W. According to Table 1, it was found that the soil with sandy texture has a slightly neutral pH. The value S for the sum of the bases is 8,8. The percentage of organic carbon (17,9) in the sandy soil is high. In relation to the (V%), it is perceived that this soil presents an excellent fertility condition.

Table 1: Physical-chemical characterization of soil

Soil Texture	pH H ₂ O	Ca ²⁺	Mg ²⁺	K ⁺	Na ⁺	Al ³⁺	H ⁺ +Al ³⁺	P (mg dm ³)	V	C.org	N
		-----cmol.dm ⁻³ -----								-----%-----	
Sandy	7.4	5.0	2.2	1.3	0.3	0.0	0.0	0.4	100	17.9	1.8

pH – hydrogen ion concentration ; Ca²⁺ – Calcium; Mg²⁺ – Magnesium; K⁺ – Potassium; Na⁺ – Sodium; S – Base Saturation (S= Ca²⁺+Mg²⁺+K⁺+Na⁺+Al³⁺); Al³⁺ – Aluminum; H⁺+Al³⁺ - *potential acidity*; P – Phosphorus ; V% - Base Saturation; C. Org – Organic Carbon; N – Nitrogen.

2.2 Vegetable oils

Bottles of 1000 mL of virgin vegetable soybean oil of the brand Lisa[®] were purchased, of the same batch of production, with validity up to 12.11.17.

2.3 System using the arduino platform

To build the prototype, a 6v source, two electrochemical sensors to measure carbon dioxide (MQ135 shield), an air temperature sensor module (DHT11), a 10k x 1 / 8w resistor (to polarize the sensor), a 16x2 LCD display with blue backlight and an Arduino[®] microcontroller model UNO were used. The Arduino[®] UNO microcontroller is a free hardware platform for electronic prototyping, in which an algorithm was introduced to measure CO₂ emission in the degradation of vegetable oil and all sensors are interconnected, as shown in figure 1.

The System for measuring the production CO₂ in soil contaminated with soybean oil using two electrochemical sensors (MQ135) connected in Arduino to a shield that facilitates the calibration of the system and applications. One of the sensors is connected to a 1m / 0.2mm flexible wire extender. An air temperature sensor (DHT11) was also used to control the ambient temperature. A resistor was used to polarize the temperature sensor. An LCD display with blue back lighting shows the sensor information, information is constantly displayed on the three sensors, changing between gas sensor (a), gas sensor and (b) air temperature sensor. The display shows the measurements using the ppm measurement units for the carbon dioxide sensors and ° C for the air temperature sensor. All sensors were embedded in a single-board of the free electronic prototyping platform (Arduino Uno). Uninterrupted operation of the system is maintained by a 6VDC / 1500mA power supply. The air temperature measurement range is between 0 ° C and 50 ° C, and the carbon dioxide measurement range is between 0ppm and 9999ppm.

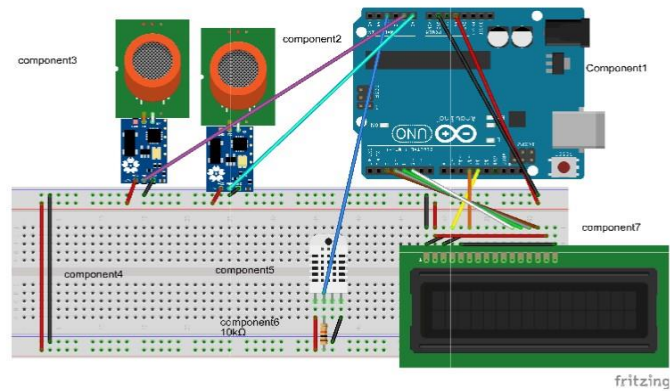

Figure 1 – Electronic schema of the prototype

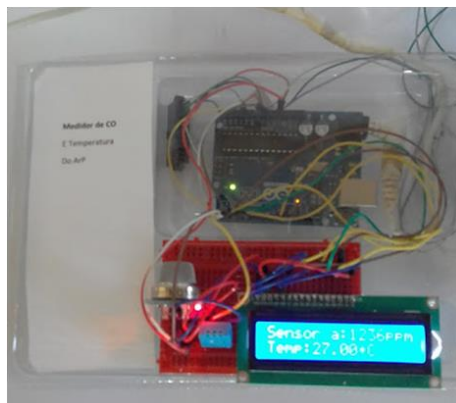

Figure 2 - System for measuring the production CO_2 in soil contaminated with soybean oil using the Arduino platform

```

co2_simples | Arduino 1.6.10
Arquivo Editar Sketch Ferramentas Ajuda
co2_simples
1 #include "DHT.h"
2 #include <LiquidCrystal.h>
3 //DHT
4 // Conecte pino 1 do sensor (esquerda) ao +5V
5 // Conecte pino 2 do sensor ao pino de A1 do Arduino
6 // Conecte pino 4 do sensor ao GND
7 // Conecte o resistor de 10K entre pin 2 (o shield ja possui o
8 // e ao pino 1 (VCC) do sensor
9
10 #define DHTPIN A3 // pino que estamos conectado
11 #define DHTTYPE DHT11 // DHT 11
12 /*Display - pino 1,3,5 e 16 no terra (NEGATIVO)
13 * pino 2 e 15 no +5v
14 * pino 4 no pino 12 do arduino
15 * pino 6 no pino 11 do arduino
16 * pino 11 no pino 5 do arduino
17 * pino 12 no pino 4 do arduino
18 * pino 13 no pino 3 do arduino

```

Salvamento cancelado.

Figure 3 – algorithm programming

The algorithm was developed to quantify the carbon dioxide produced by the degradation of the oil in the contaminated soil and verify the temperature of the environment, as shown in figure 3.

The operation basically consists of: after introducing the libraries (specific commands for each sensor) and the polarization of the ports (pins of the Arduino board), the following message is sent to the user: "Heating the Sensor:". Then, the gas sensor (a) obtains a reading in (volts) and converts it to (ppm), which is shown to the user through the LCD display. Then, the same process is performed with the gas sensor (b). Thus, on the display the gas measurements are changing between the carbon dioxide sensors a and b. The temperature sensor measurements obtained in (volts) are converted to ($^{\circ}$ C). The information is displayed on the display constantly.

2.4 Methods

For performing this experiment, we weighed in a 2 liters pot 500 g of soil (Table 1) artificially contaminated with 25 ml of virgin soybean oil. Subsequently, a CO₂ capture sensor was introduced and every 15 days, the generated CO₂ production was read in ppm on the liquid crystal display (Figure 2). The experiment lasted 90 days and 6 evaluations were done.

2.5 Statistical analysis

The averages of CO₂ production the were calculated through Tukey's test used to evaluate the significance at 0.05 (5% probability) among them (COSTA NETO, 1977; MILLER; MILLER, 1993).

All calculations and graphs presented in this work were performed by SigmaPlot 12.5 software.

3. Results and Discussion

The average values of the capture of CO₂ as a function of the different periods of analysis are shown in graphic 1. For the first period of analysis (15 days), it was found that the average CO₂ production was 200 ppm. For the second and third analysis periods (30 and 45 days) the average CO₂ production presented a reasonable increase (405 and 808 ppm). However, at 60 days the measured output reached its peak (1140 ppm). The quadratic function described shows a decrease in CO₂ production from the fourth analysis period (60 days), tending to zero after the last analyzed period (90 days). This function has a satisfactory level of confidence with $R^2 = 0.8632$. Significant differences were observed between the production of CO₂ as a function of time by the Tukey test ($p < 0.05$).

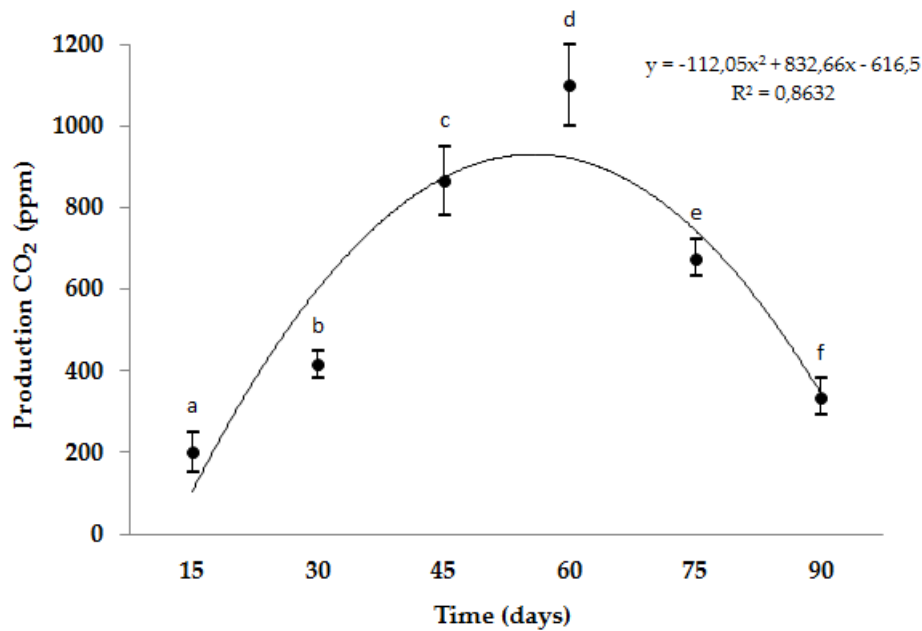

Graph 1. Evaluation of production of CO₂ in different periods of time. Averages values followed by the same lowercase letter do not differ statistically from each other by Tukey test ($p < 0.05$).

Muligan e Yong (2004) report that the process of natural attenuation of an organic soil pollutant, without adding nutrients or adequacy of any environmental condition, can occur continuously due to the process of natural adaptation of the native microbiota of the impacted soil. These microorganisms then use the organic pollutant as a source of carbon, thereby reducing their concentration over time.

Thode-Filho et al (2015) did a biodegradation study of virgin soybean oil in clayey soil and found that the maximum CO₂ production occurred around the thirtieth day and the CO₂ reduction was at zero after 60 days of experiment. This result suggests that aerobic microorganisms have a direct participation in the pollutant consumption. Fast-growing aerobic bacteria must have consumed all of the O₂ in the bottle by the thirtieth day. After this period, only the anaerobic bacteria participated in the process and did not produce CO₂, since they do not use oxygen as an electron acceptor. Such behavior was also observed in the present study, but CO₂ production occurred until the fifth period of analysis (60 days).

4. Conclusion

With regard to the results obtained in the research that supported in this article, it is verified that virgin soybean oil is biodegraded in the soil, even under anaerobic conditions. The peak CO₂ production was 60 days (1140 ppm).

The developed system fulfills the proposed objectives and is in accordance with the examples found in literature. In addition, it has been shown to be an efficient and low-cost system that quantitatively monitors the CO₂ produced in the degradation of vegetable oil in contaminated soil. The intention is also to continue the project, measuring the degradation of other pollutants in soil in an efficient and quantitative way. Therefore, our prototype will undergo several modifications and improvements in its operation, including the monitoring of the results of temperature sensors and relative humidity to follow this process, measuring the environmental variables.

5. References

- ABIOVE. *Associação Brasileira das Indústrias de Óleos Vegetais*. 2014. Disponível em: <http://www.abiove.com.br/menu_br.html>. Acesso em: 18 jan. 2016.
- AGARRY, S. E.; AREMU, M. O.; AWORANTI, O. A. Soil Washing Remediation of Soil Artificially Contaminated with Naphthalene: Evaluation of Palm Kernel Oil, Coconut Oil and Waste Cooking Oil as Solubilization Agents. *American Journal of Environmental Engineering*, Los Angeles, 2013. v. 3, n. 2, p. 85-94.
- BRAGA, B. *et al.* (2002). *Introdução à engenharia ambiental*. São Paulo: Prentice Hall. p. 145-150.
- COSTA FILHO, Gerson Felipe da - *Biodegradação de óleos derivados do petróleo e de origem vegetal estimulada por biossurfactantes em meio aquoso e monitoramento de sua toxicidade - Rio Claro* : [s.n.], 2011 64 f. : il., figs., gráfs., tabs.
- COSTA NETO, P.L.O. **Estatística**. São Paulo: Edgard Blücher, 1977. 264p.
- GALBIATI, A. F. *O gerenciamento integrado de resíduos sólidos e a reciclagem*. 2005. Minas Gerais, Disponível em: <<http://www.redeaguape.org.br>>. Acesso em: 21 jul. 2017.
- GONG, Z. *et al.* Dissolution and removal of PAHs from a contaminated soil using sunflower oil. *Chemosphere*, v. 58, n. 3, p. 291-298, 2005a.
- GONG, Z. *et al.* Influence of soil moisture on sunflower oil extraction of polycyclic aromatic hydrocarbons from a manufactured gas plant soil. *Science of the total environment*, v. 343, n. 1, p. 51-59, 2005b.
- LOUREIRO, S.; SOARES, A.M.V.M.; NOGUEIRA, A.J.A. Terrestrial avoidance behaviour tests as screening tool to assess soil contamination. *Environ Pollut*, v. 138, p. 121-131, 2005.
- MILLER, J.C., MILLER, J.N. **Statistics for analytical chemistry**. 3a ed. Chichester: Ellis Horwood. 233p., 1993.
- MULLIGAN, C. N.; YONG, R. N. (2004). Natural attenuation of contaminated soil. *Environmental International*, Oxford, v.30, n. 4, p. 587-601, Apr.
- RABELO, R. A.; FERREIRA, O. M. *Coleta seletiva de óleo residual de fritura para aproveitamento industrial*, 2008. Disponível em: <<http://www.ucg.br>>. Acesso em 14 abr. 2017.
- SABESP. *Programa de Reciclagem de Óleo de Fritura da SABESP*. Disponível em: <http://site.sabesp.com.br/uploads/file/asabesp_doctos/programa_reciclagem_oleo_completo.pdf>. Acesso em: 27 fev. 2017.
- THODE FILHO, S., Moraes de Almeida, T., Santos da Paixão, C. P., da Costa Marques, M. R., & Rodrigues da Silva, E. (2015). Biorremediação passiva: um estudo preliminar sobre o óleo vegetal de soja. *Ciência e Natura*, 37(2).